

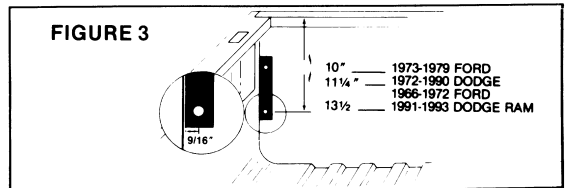

FRONT ANCHOR INSTALLATION

1. Making certain of correct hole position for your truck model (see Fig. 3), mark and drill bottom hole (to prevent drill from drifting, drill small pilot hole first and then enlarge to 3/8"). Connect Anchor Plate (Fig. 2) with lower bolt prior to drilling top hole.
2. Rotate Anchor Plate slightly outward so the plate threads are not damaged while drilling top hole.
3. With tightened lower bolt to hold guide strap firmly in place, drill top hole* (drill small pilot hole first and enlarge to 3/8").
4. Loosen bottom bolt to allow top bolt to start easily, then tighten bolts.

* When stake pocket prevents top hole from being drilled at straight angle, drill hole at the best angle permissible. The hole angle can easily be straightened to 90° by placing the 3/8" section of rod (included for this purpose) through the hole and tapping it with a hammer in the direction needed to straighten the hole.

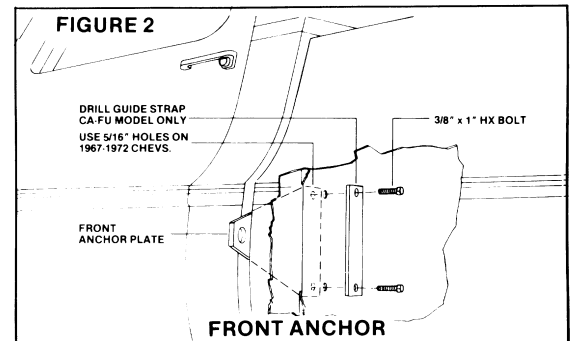
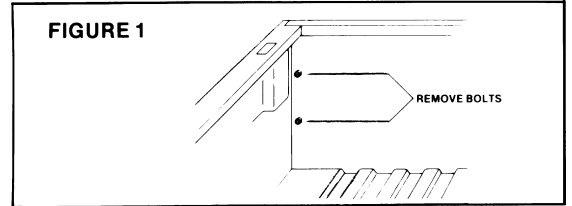

1967-1972 Chevrolet/GMC Installation

1. Remove the two bolts on each side of the front truck panel (as shown in Fig. 1).
2. Insert the front Anchor Plate (Fig. 2). Secure with the same bolts removed. Use the smaller (5/16") holes in the front Anchor Plate. The 3/8" bolts provided fit another truck model and may be discarded.

REAR ANCHOR INSTALLATION

1. Locate universal rear anchor such that the alignment is as nearly vertical below the camper eye-bolt as possible, and low enough to allow sufficient space between eye-bolt and rear anchor for turnbuckle installation (generally 13"-18"). **WARNING:** Before drilling check for clear access to the backside between outer fender and bed wall, and check for any wires, fuel lines, etc.
2. Drill small pilot hole and enlarge to 1/2".
3. Tightly secure chrome anchor bolt with large fender washer, lock-washer, and nut (Fig. 4)
4. Removable Tiedown Coupler connects turnbuckle to anchor.

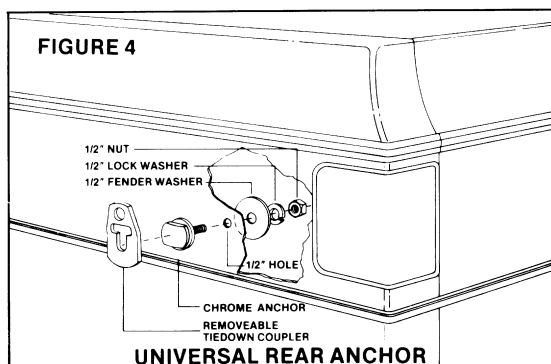

Customer Service Numbers:
 Web: www.happijac.com
 Phone: (800) 231-7440
 (801) 544-2585
 Fax: (801) 546-5241
 Email: happijac@happijac.com